

CHEMICAL PUMPS SINCE 1992

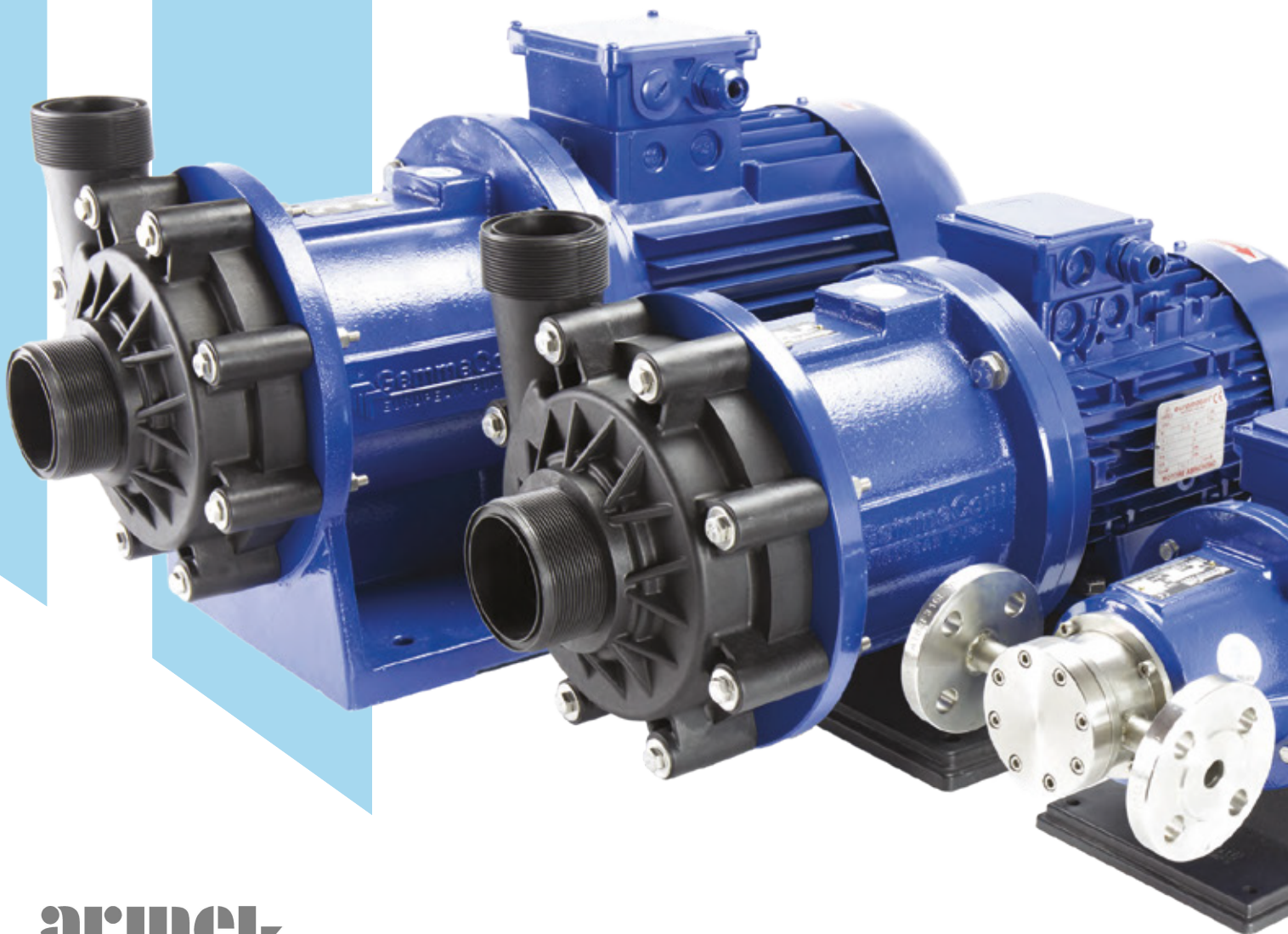

arnek
GemmeCotti Group

GemmeCotti
EUROPEAN PUMPS

GENERAL
CATALOGUE

2022/23

MAG-DRIVE TURBINE PUMPS

SEAL-LESS MAG DRIVE TURBINE PUMPS

In seal-less magnetic drive turbine pumps, the external magnet is directly connected to the motor shaft and it transmits the torque to the internal magnet.

The magnetic field created produces a rotation without physical contact between the parts and the turbine spins and moves the fluid. The rear casing is placed between the two magnet joints and it hermetically closes the hydraulic part from the motor.

GemmeCotti supplies three different models of mag drive turbine pumps:

HTT

- Thermoplastic pumps made of PP or PVDF.
- Capacity up to 9 m³/h.
- Head up to 50 mlc.

HTT-SP

- Thermoplastic pumps made of PP or PVDF.
- Capacity up to 7 m³/h.
- Head up to 25 mlc.

- Machined from a block.
- Self-priming up to 3 m.

HTA

- Metallic pumps made of stainless steel AISI316.
- Capacity up to 7 m³/h.
- Head up to: 80 mlc.

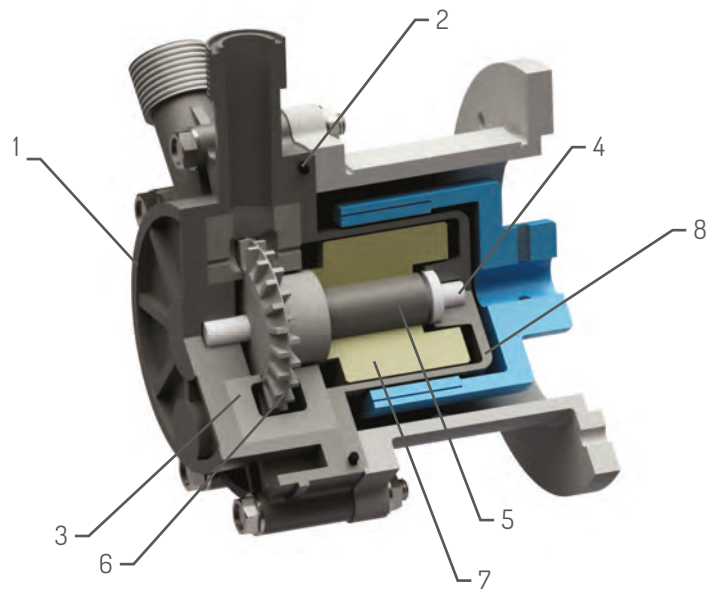

MATERIALS IN CONTACT WITH THE LIQUID

PART NUMBER - DESCRIPTION	TURBINE PUMPS		
	HTT	HTT-SP	HTA
1 - PUMP HEAD	PP OR PVDF	PP OR PVDF	AISI 316
2 - O-RING	EPDM OR VITON	EPDM OR VITON	EPDM OR VITON
3 - FRONT AND REAR DISC	PP OR PVDF	PP OR PVDF	PTFEC
4 - SHAFT + RING	CERAMIC Al ₂ O ₃ 99,7%	CERAMIC Al ₂ O ₃ 99,7%	HASTELLOY-C 276
5 - BEARING	PTFEC	PTFEC	PTFEC
6 - IMPELLER	PVDF	PVDF	AISI 316
7 - INTERNAL MAGNET	PP OR PVDF + NdFeB	PP OR PVDF + NdFeB	AISI 316 + SmCo
8 - REAR CASING	PP OR PVDF	PP OR PVDF	

THERMOPLASTIC MAG-DRIVE REGENERATIVE TURBINE PUMPS



STANDARD:

- Gas threaded In and Out connections.
- Static shaft in high purity ceramic.
- Chemical resistant PTFE/carbon sleeve bearings.
- High torque magnetic coupling.
- Direct starting motor.

OPTIONAL:

- DIN or ANSI 150 flanges available.
- Baseplate.
- Dry-running protection device.
- Available in ATEX version for zone 2 II3G (pump mod. EM-T PP/PVDF).

Mag drive regenerative turbine pumps series HTT are made of thermoplastic materials (polypropylene-PP and PVDF) and are suitable for pumping high corrosive liquids. Thanks to the innovative mag drive system, pumps model HTT reduce risks of leakage and emissions and the maintenance costs. The transmission of the motion occurs through magnetic joints without any mechanical seal. This sealless design guarantees the maximum safety and efficiency. The pumped liquid has to be clean and without solids in suspension.

MAIN FEATURES

- Materials available: PP / PVDF.
- Plastic injection moulded
- Materials in contact with the liquid: casing and rear casing: PP/PVDF; Impeller: PVDF; o-ring: EPDM (standard for PP pumps); VITON (standard for PVDF pumps); shaft: Al203 99,7%; bearing: PTFEC.
- Max flow: 9 m³/h; Max head 50 m.
- Temperature: PP: max 70°C – PVDF: max 90°C.
- Max viscosity: 40 cPs.
- Pressure rating: NP 6.
- It handles up to 20% entrained gas. HTT pump resists cavitation.

PERFORMANCE CURVES 50HZ - 2900 RPM

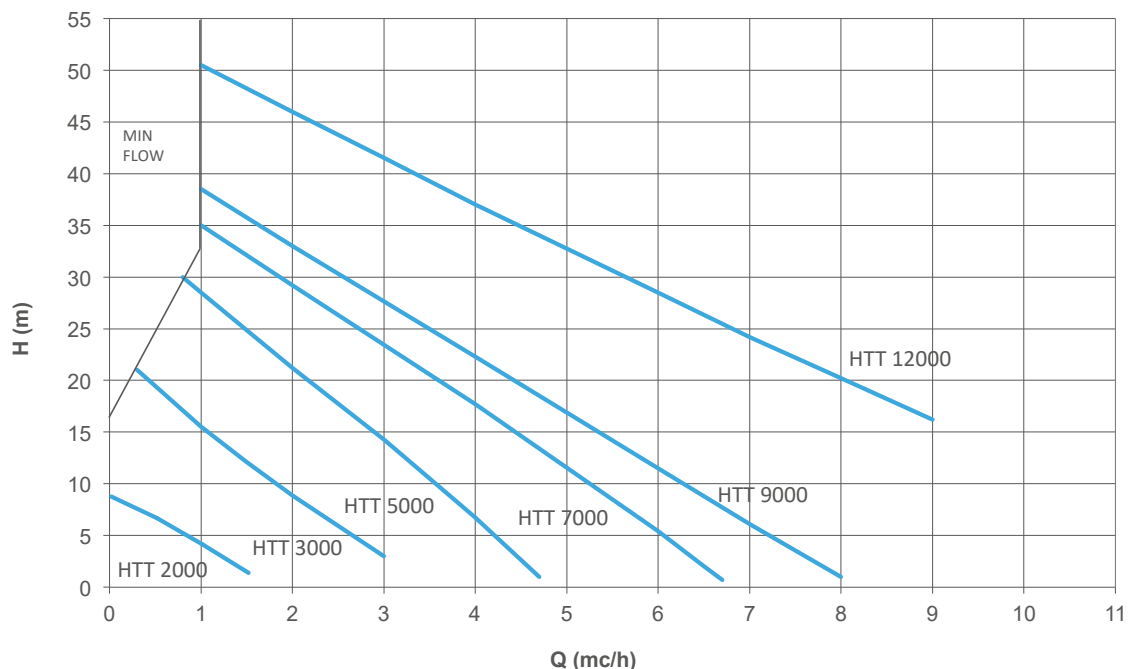

HTT TECHNICAL DATA

PUMP SIZE	MATERIAL	Q MAX		H MAX		SUCTION CONNECTION	DISCHARGE CONNECTION	PUMP WEIGHT (KG)		SUITABLE MOTOR POWER (Kw) - 2900 rpm	MOTOR FLANGE AND FRAME
		50HZ (M3/H)	60HZ (USGPM)	50HZ (MLC)	60HZ (FT)			PP	PVDF		
HTT 2000	PP- PVDF	1.7	8.8	10	50	1" MALE	1" MALE	2.8	3.8	0,37	71 - B3/B5
HTT 3000	PP- PVDF	3	15	21	102	1" MALE	1" MALE	2.8	3.8	0,37	71 - B3/B5
										0,55	71 - B3/B5
HTT 5000	PP- PVDF	5	26	30	140	1 1/2" MALE	1 1/2" MALE	8	10	0,75	80 - B3/B5
										1,1	80 - B3/B5
HTT 7000	PP- PVDF	7	37	36	162	1 1/2" MALE	1 1/2" MALE	8	10	1,1	80 - B3/B5
										1,5	90 S - B3/B5
										2,2	90 L - B3/B5
HTT 9000	PP- PVDF	8	41	36	177	1 1/2" MALE	1 1/2" MALE	8	10	2,2	90 - B3/B5
										3	100 - B3/B5
HTT 12000	PP- PVDF	9	42	48	235	1 1/2" MALE	1 1/2" MALE	8	10	3	100 - B3/B5
										4	112 - B3/B5

HTT 2000 - 3000 - 5000 - 7000 - 9000 - 12000 PP/PVDF DIMENSIONS

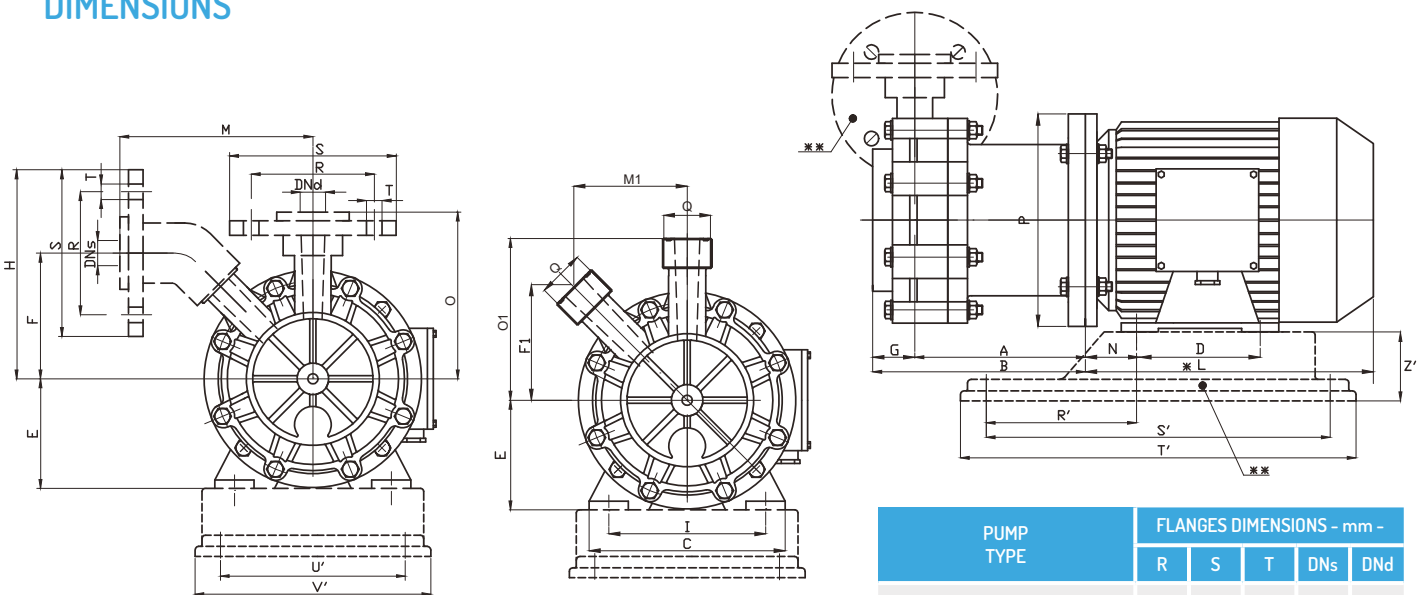

PUMP TYPE	FLANGES DIMENSIONS - mm -				
	R	S	T	DNs	DNd
HTT 2000 - 3000	85	115	14	25	25
HTT 5000 - 7000 - 9000 - 12000	110	153	18	40	40

PUMP TYPE	MOTOR FLANGE B3 - B5	KW	DIMENSIONS - mm -															BASEPLATE DIMENSIONS - mm -								
			A	B	C	D	E	F	F1	G	H	I	*L	M	M1	N	O	O1	P	Q	R'	S'	T'	U'	V'	Z'
HTT 2000	71 A	0.37	118	146	142	90	71	86	78	28	145	112	192	135	78	45	116	110	160	1" MALE	112	244	280	130	160	48
	71 B	0.55	118	146	142	90	71	86	78	28	145	112	215	135	78	45	116	110	160	1" MALE	112	244	280	130	160	48
HTT 5000	80 A	0.75	187	221	160	100	80	110	95	34	187	125	215	189	95.5	50	148	135	200	1 1/2" G MALE	120	302	350	157	205	60
	80 B	1.1	187	221	160	100	80	110	95	34	187	125	232	189	95.5	50	148	135	200	1 1/2" G MALE	120	302	350	157	205	60
HTT 7000	90 S	1.5	187	221	170	100	90	110	95	34	187	140	255	189	95.5	56	148	135	200	1 1/2" G MALE	120	302	350	157	205	60
	90 L	2.2	187	221	170	125	90	110	95	34	187	140	280	189	95.5	56	148	135	200	1 1/2" G MALE	132	302	350	157	205	60
HTT 9000	100	2.2	187	221	170	125	90	110	95	34	187	140	280	189	95.5	56	148	135	200	1 1/2" G MALE	132	302	350	157	205	60
	100	3	207	241	200	140	100	110	95	34	187	160	315	189	95.5	63	148	135	250	1 1/2" G MALE	140	352	400	202	250	60
HTT 12000	100 L	3	207	241	200	140	100	110	95	34	187	160	315	189	95.5	63	148	135	250	1 1/2" G MALE	140	352	400	202	250	60
	G 112 M	4	207	241	230	112	110	95	34	187	190	324	189	95.5	70	148	135	250	1 1/2" G MALE	156	352	400	202	250	60	

* Different according to the manufacturer. ** OPTIONAL UPON REQUEST: Baseplate - Flanges.
 NOTE: DIRECTION OF ROTATION IS COUNTER CLOCKWISE AS SEEN WHEN FACING THE MOTOR.
 PUMPS AVAILABLE THREADED OR FLANGED.